

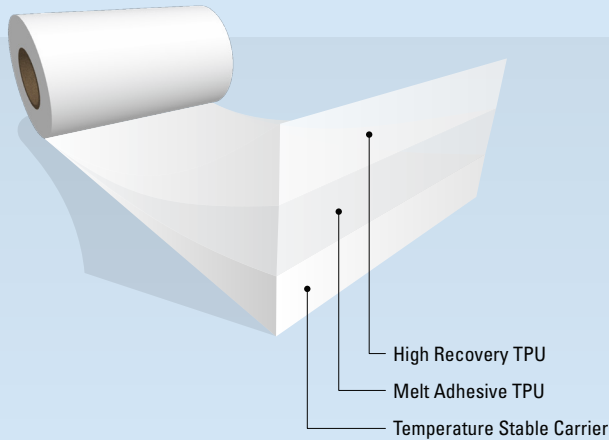

DUPONT™ INTEXAR™ TE-11C

BASE FILM FOR WEARABLES APPLICATIONS

Base Film TE-11C



PRODUCT DESCRIPTION

DuPont™ Intexar™ TE-11C is a stretchable bilayer thermoplastic polyurethane (TPU) film. TE-11C is comprised of high recovery and melt adhesive layers optimized for high stretch smart clothing applications like fitness and health monitoring when wearer comfort is paramount. The high recovery layer is specially designed for compatibility with Intexar™ stretchable electronic ink printing. The melt adhesive layer is designed for bonding to fabrics under heat press lamination. The film is supplied on a temperature stable polypropylene carrier for high throughput sheet-fed or roll-to-roll screen printing.

PRODUCT BENEFITS

- High recovery, light weight, stretchable TPU
- Designed for compatibility with Intexar™ stretchable electronic inks
- Bonds strongly to most fabrics and compatible with Cover Film TE-21C
- Soft to the touch, designed for comfort

Example of Clamshell Style Press

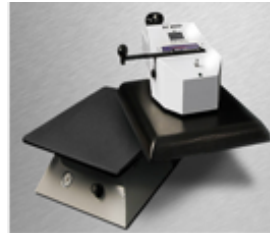

Example from <http://geoknight.com/>

Lay-up in Laminator

Heating Plate
Parchment Paper
Base Film
Fabric
Parchment Paper
Laminator Base

PROCESSING GUIDELINES

- Trim to required size for print
- After printing is completed on TE-11C, remove the carrier layer
- Bond TE-11C to fabric by laminating in a clamshell style press with uniform platen temperature & pressure:
 - Use parchment paper to avoid air entrapment during lamination
 - Temperature set-point 125 – 135°C (expect 5 – 10°C offset between set-point and maximum temperature achieved during bonding process)
 - Dwell time 15 – 30 seconds
 - Pressure 414 - 483 kPa gauge pressure (60 – 70 psig)
- Fabric lamination requirements vary and not all fabrics are compatible

ROLL LENGTHS & WIDTHS

Roll Width (mm)	Roll Length (m)	
406	100	500
610	100	500
813	100	500
1473	100	500

Roll Width (in)	Roll Length (yd)	
16	109	547
24	109	547
32	109	547
58	109	547

Other dimensions may be available upon request, please contact local sales agent.



DUPONT™ INTEXAR™ TE-11C BASE FILM FOR WEARABLES APPLICATIONS

BASE FILM TYPICAL PROPERTIES: TE-11C

Typical Properties	Value
Color	Translucent clear
High Recovery Layer Thickness	50 – 75 µm
Melt Adhesive Layer Thickness	25 – 50 µm
Recovery ¹	97%
Modulus ²	(40%) 4.3N (100%) 6.2N
Shore A Hardness	71
Melt Adhesive glue line temperature	130°C
Roll Length ³	100 – 500 m
Roll Width ³	406 – 1473 mm

¹Recovered strain after 40% strain at 508mm/min, 1 second rest

²Force required to pull 2cm wide 100µm thick film to specified strain after first cycle

³Refer to Roll Lengths & Widths Tables above for details

STORAGE AND SHELF LIFE

Rolls should be stored in a clean stable environment at room temperature (<25°C).

SAFETY AND HANDLING

For Safety and Handling information, please refer to the Article Information Sheet.

FOR MORE INFORMATION ON DUPONT™ INTEXAR™ TE-11C OR OTHER DUPONT PRODUCTS, PLEASE CONTACT YOUR LOCAL REPRESENTATIVE:

Americas

E.I. DuPont
Chestnut Run Plaza, B708
974 Centre Rd, Wilmington, DE 19805
U.S.A
Tel. +1919 248 5188

Europe, Middle East & Africa

DuPont (U.K.) Ltd
Bristol & Bath Science Park
Dirac Crescent, Emersons Green
Bristol, BS16 7FR
U.K.
Tel. +44 117 9709667

Asia

DuPont Electronic Materials K.K.
KSP R&D B213, 2-1
Sakado 3-chome, Takatsu-ku,
Kawasaki-shi, Kanagawa, 213-0012
Japan
Tel +81 44 820 7575

DuPont Taiwan Ltd
45, Hsing-Pont Road
Taoyuan, 330
Taiwan
Tel. + 886 3 377 3616

DuPont China Holding Co. Ltd
B11, 399 Keyuan Road
Zhangjiang Hi-Tech Park
Pudong New District,
Shanghai 201203
China
Tel. +86 21 3862 2888

DuPont Korea Inc.

3-5th Floor, Asia tower #726,
Yeoksam-dong, Gangnam-gu
Seoul 135-719,
Korea
Tel. +82 2 2222 5275

E. I. DuPont India Private Limited

7th Floor, Tower C, DLF Cyber Greens,
Sector-25A, DLF City, Phase-III
Gurgaon 122 002 Haryana, India
Tel. +91 124 4091818

DuPont Company (Singapore) Pte Ltd

21 Biopolis Road
#06-21 Nucleos South Tower
Singapore 138567
Tel. +65 6586 3022

advancedmaterials.dupont.com

Copyright © 2017 DuPont. All rights reserved. The DuPont Oval Logo, DuPont™, and all DuPont products denoted with ® or ™ are registered trademarks or trademarks of E. I. du Pont de Nemours and Company or its affiliates.

This information corresponds to our current knowledge on the subject. It is offered solely to provide possible suggestions for your own experimentations. It is not intended, however, to substitute for any testing you may need to conduct to determine for yourself the suitability of our products for your particular purposes. This information may be subject to revision as new knowledge and experience becomes available. Since we cannot anticipate all variations in end-use conditions, DuPont makes no warranties, and assumes no liability in connection with any use of this information. Nothing in this publication is to be considered as a license to operate under or a recommendation to infringe any patent right.

CAUTION: Do not use in medical applications involving permanent implantation in the human body. For other medical applications, see "DuPont Medical Caution Statement," H-50102-5.

K-29776 (11/17)